

STATIC DIMENSIONS

CUSTOMER

CUSTOMER NAME

PROJECT

CUSTOMER PROJECT

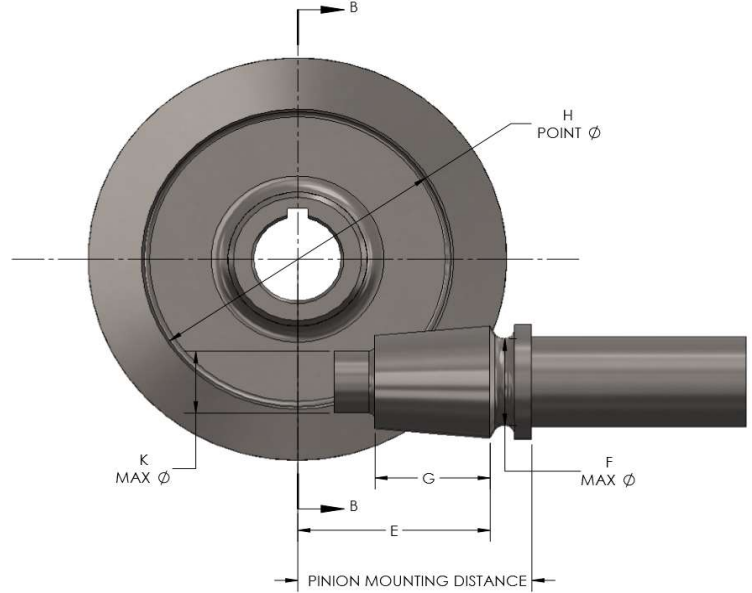
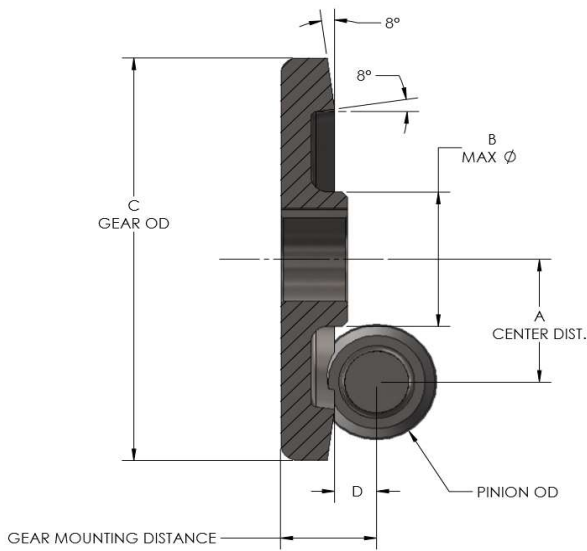

A	0.685
D	0.106
G	0.487

B	1.000
E	0.704
H	1.460

C	1.875
F	0.350
K	0.300
Pinion OD	0.500

*All dimensions in inches

CUSTOMER	CUSTOMER NAME		
PROJECT	CUSTOMER PROJECT		
GEAR O.D.	1.875	RH / LH	LH
RATIO (TO 1)	31	GEAR MATERIAL	STEEL
GEAR TYPE	SPIROID	CUTTING TOOL	52-417

