

# STATIC DIMENSIONS

CUSTOMER

CUSTOMER NAME

PROJECT

CUSTOMER PROJECT

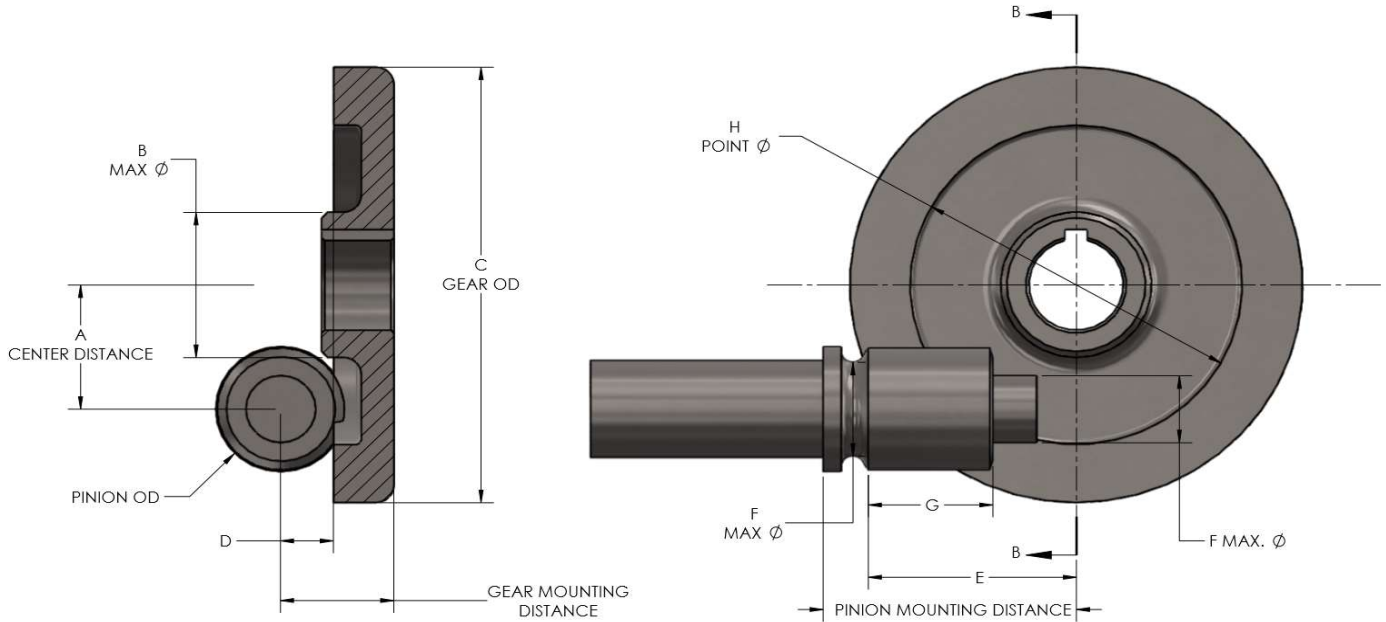

A	0.685
D	0.106
G	0.487

B	1.000
E	0.704
H	1.460

C	1.875
F	0.180
Pinion OD	0.312

\*All dimensions in inches

CUSTOMER	CUSTOMER NAME		
PROJECT	CUSTOMER PROJECT		
GEAR O.D.	1.875	RH / LH	RH
RATIO (TO 1)	31	GEAR MATERIAL	STEEL
GEAR TYPE	HELICON	CUTTING TOOL	52-417

